

# LONGWALL ROOF CONTROL BY CALCULATION OF THE SHIELD SUPPORT REQUIREMENTS

Ulrich Langosch <sup>1</sup>, Ulrich Ruppel <sup>1</sup>, Uwe Wyink <sup>1</sup>

*ABSTRACT:* In the 1990s the German mining industry introduced a new generation of shield supports. The new design of support has a maximum load capacity of 10,000 kN, making these units as strong as the shields used in Australia and in the USA. Deutsche Montan technologie (DMT) took more than 3,100 underground observations in order to verify the roof fall frequency by statistical analysis. The results of this work have led to practical recommendations for roof control and the required shield support system on longwall faces.

The underground observations have been correlated to Rock Mass Classification, to stress calculations and to the angle between the direction of the fissures and the direction of longwall mining. The analysis work yielded the following two sets of results:

1. There is a critical distance between the canopy tip and the coal face Tip to Face ( $TF_{crit}$ ). The  $TF_{crit}$  is predictable and relates to:
  - the thickness of the first roof layer and
  - its uniaxial compressive strength.

The face support should have a Tip to Face (TF) that is less than the  $TF_{crit}$  in every underground longwall situation. Exceeding the  $TF_{crit}$  can immediately result in a roof fall.

2. Using the obtained regression equation DMT is able to calculate the probability of the Roof Fall Frequency (RFF), which describes the roof fall sensitivity. When  $TF_{crit}$  is exceeded the predicted FF relates to:
  - the Measured Support Resistance (MSR) of the shield support
  - the calculated vertical stress ( $p_v$ )
  - the Fissure-Direction Index (FDI) which equals the angle between main fissure direction and direction of mining and
  - the distance by which  $TF_{crit}$  is exceeded ( $\Delta TF$ )<sub>crit</sub>.

Armed with these results DMT is now able to predict the critical distance between the tip of the canopy and the coal face ( $TF_{crit}$ ), as well as the RFF, for all shield designs.

By applying the new calculation method it is now possible to compare alternative longwall layouts and different shield support types under pre-set geological conditions. Mining engineers on site are therefore in a position to make the necessary roof control preparations required to run the longwall operation to maximum efficiency. The results provide a useful basis for making practical recommendations and for selecting the most effective design of shield support.

Practical examples to demonstrate the R&D results and present the various methods now available for calculation and prediction in longwall roof control are presented.

## INTRODUCTION

Prior to 1990 the German coal industry employed shield supports that were notable for their lightweight' compact design and high-strength steel construction (Figure 1). This meant that the 2-leg shields weighed in at a relatively light 10 to 15 tonnes. The maximum support load was between 5,000 and 6,000 kN. Most of these supports were fitted with jointed canopies with slide bars (extensible forepoles) to improve the contact between the canopy and

---

<sup>1</sup> Deutsche Montan Technologie GmbH

the often undulating roof beds. A process for evaluating the anticipated roof falls was already in place for this generation of shields as long ago as 1980 (Jacobi, 1981)

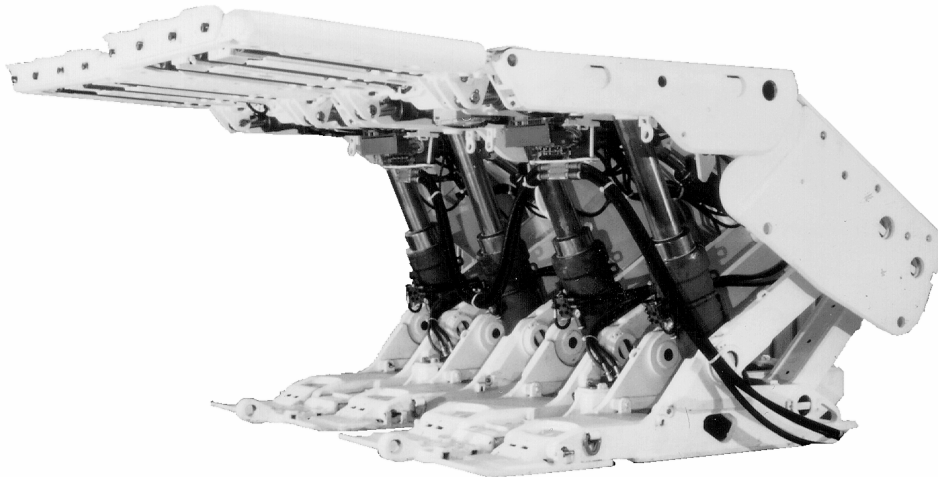

**FIG. 1 - Shield support design in the 1980s**

Some ten years ago the discussion in Germany began to focus intensively on the positive experience obtained in the USA and Australia with rigid, one-piece canopies and much higher maximum support loads that in some cases exceeded 10,000 kN. Around about the mid-1990s this resulted in a standardisation of shield support systems in the German coal industry. Nowadays the supports purchased by the industry are exclusively 2-leg shield units with one-piece roof canopies and support loads of up to 10,000 kN – these being subdivided into four categories for seam thickness (Figure 2). Most of the new standard shield designs also avoided using high-strength steels, which in some cases had increased the weight of the units to as much as 20 tonnes.

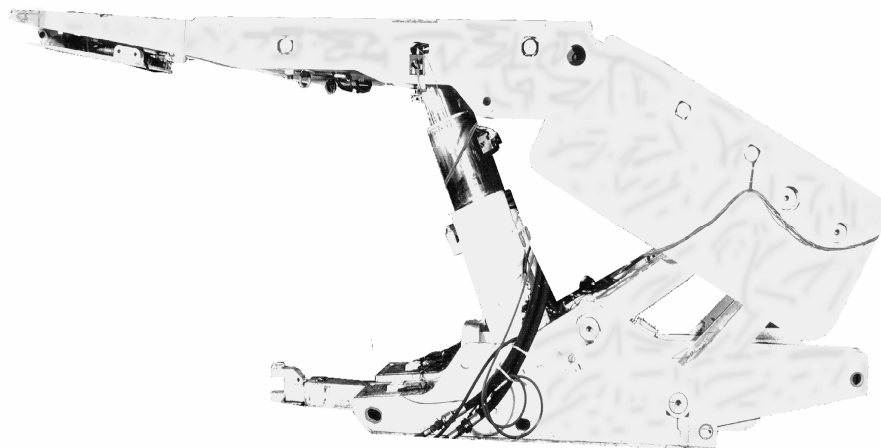

**FIG. 2 - Shield support design since the mid-1990s**

These standard shield supports are to be installed on all coal faces in Germany in the course of the next few years. However, as quite a few of the “old shields” are currently still in existence, the question arose as to the type of geological conditions under which it would be imperative to use the new standard units. In addition to this, the old shield designs currently in operation still have to be employed to optimum effect for the remainder of their useful life under the given operating conditions.

As part of a research project carried out by Deutsche Steinkohle AG (DSK) a new system was developed for calculating the influence of the measured support resistance on the coal-face roof control process. This roof control process was quantified on the basis of the RFF of the roof beds. The RFF is a yardstick for the tendency of the roof to collapse.

In spite of all the advances in IT development a problem of this type cannot fully be resolved by means of numerical simulation. Such an operation would require universally applicable model concepts to represent the development of the roof-fall process and the ways in which this can be influenced. Even today this information can only be obtained under practical conditions, with underground coal faces acting as real-life test beds.

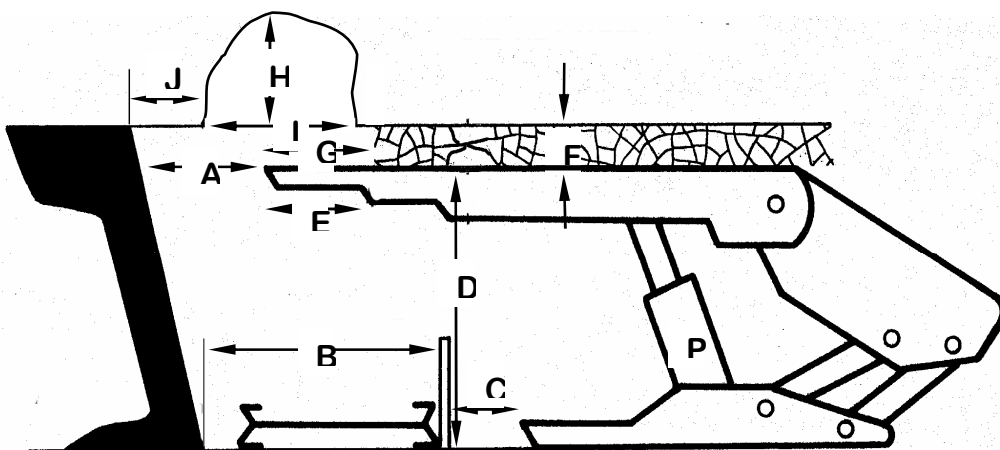

FIG. 3 - Physical longwall model

Underground measurements taken on current production faces were therefore used as a basis for the investigations. The caving behaviour of the roof beds under longwall conditions was derived from existing physical models (Figure 3). These model concepts were then examined on the basis of the underground measurements. Only by applying these underground measurements was it then possible to develop regression analyses for determining the roof-fall frequency as an indicator for the actual roof control system.

#### LONGWALL DATABASE

The research project involved taking underground measurements using the "longwall observation method", which has been a recognised technique for at least 30 years (Figure 4), and then storing this information in a longwall database (Jacobi, 1981). The longwall observation method includes, for example, fixing the position of the face conveyor and supports in relation to the coal face by taking three distance measurements, namely coal face to conveyor, conveyor to tip of skid and canopy tip to coal face. Other measurements taken include the extended shield height, the hydraulic pressure in the two shield legs and the canopy and skid inclination. If roof fall cavities are present, records are taken of their height and width. A data bank of this kind provides a very accurate description of how each shield functions in reaction to the current operating situation. Measurements are not taken from each and every shield along the face line. By surveying every eighth or tenth shield it is possible to obtain a representative picture of the condition of the face supports and roof strata at a certain face position.



### Measured distances, heights & widths

- |                             |                         |
|-----------------------------|-------------------------|
| A: Tip canopy to face (TF)  | D: Shield height        |
| B: Conveyor to face         | E: Extension forepole   |
| C: Tip base to conveyor     | F: Height stone cushion |
| G: Tip canopy to 1.abutment | H: Fall height          |
| J: Face to fall             | I: Fall width           |
| p: Leg pressure left/right  |                         |

**FIG. 4 - Underground longwall observation method**

Figure 5 shows the DMT longwall database measurements available for our evaluations. In all a total of 14 production faces were investigated. Some 135 to 315 individual measurements were carried out on each face, making an overall total of 3,137 observations. This body of data represents a representative cross-section of longwalls operating at depths of 800 to 1,200 metres and equipped with a wide variety of different shield support designs.

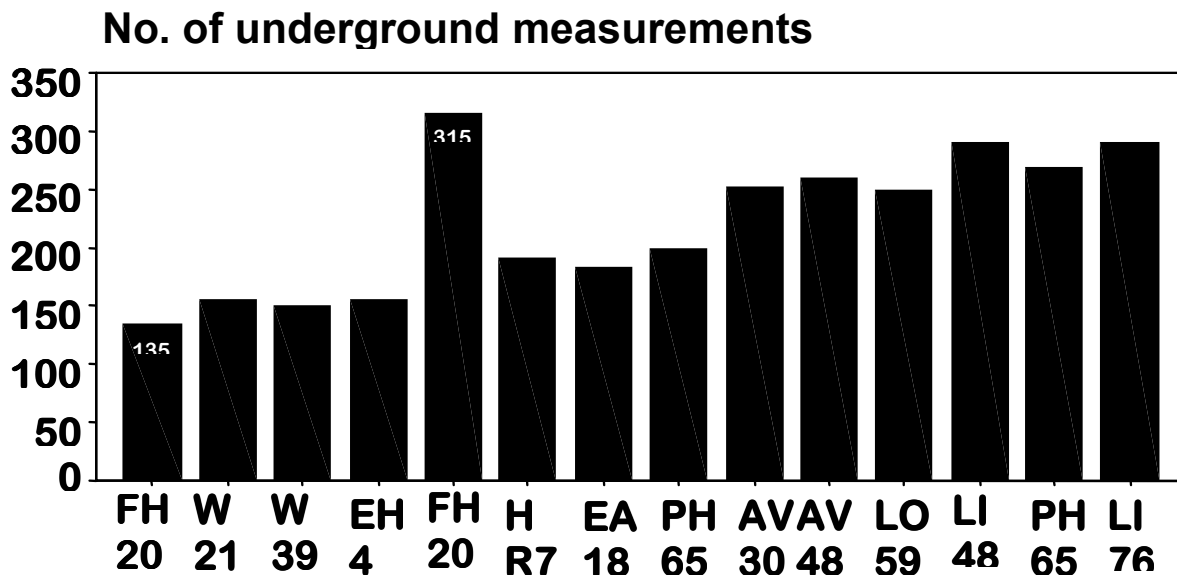

**FIG. 5 - Longwall database**

A number of technical terms, which are essential for understanding the analysis are discussed below (Iresberger, Grawe, Migenda, 1992):

#### **Roof Fall Frequency FF (%)**

The measured Roof Fall Frequency ( $RFF_{\text{measured}}$ ) is the ratio of the number of observed shields with roof falls to the total number of observed shields per face. This value cannot be relayed by remote data transfer to the surface, even when using electrohydraulic shield controls, but can only be measured underground.

The calculated Roof Fall Frequency ( $RFF_{\text{calculated}}$ ) describes the probability (in %) that a roof fall will occur at a specific place and is a criterion for the roof-fall sensitivity of the roof beds (Jacobi, 1981, Iresberger, Grawe, Migenda, 1994).

#### **Theoretical Support Resistance (TSR) ( $\text{kN/m}^2$ )**

The TSR is the calculated theoretical support load of a shield in relation to the supported roof canopy surface up to the coal face. When calculating the TSR, different values are used at international level for the support load in kN (leg setting load or yield load), in relation to the roof area in  $\text{m}^2$  (shield in back or in forward position) (Peng, Chiang, 1984).

### Measured Support Resistance (MSR) ( $\text{kN/m}^2$ )

The MSR is calculated using measurements obtained underground. This takes account of the measured leg pressure in relation to the actual area of roof surface available. The calculation process includes the roof area, which is determined from the measured face width (specified canopy length plus measured distance between canopy tip and coal face) multiplied by the width of the shield.

The MSR is generally smaller than the more theoretical CSR. However, MSR is of decisive importance for roof control and for roof fall frequency on the face, as it describes the support loads actually transferred to the roof. Our investigations were therefore based exclusively on an evaluation of the measured values MSR.

### ROOF FALL GEOMETRY

A good overview of the roof fall geometry is shown in Figure 6, in which the measured height of a roof fall on the face is plotted against the respective distance between roofbar tip and coal face (Jacobi, 1981). It is clear that roof falls only occur when a certain tip to face distance is exceeded – in this case the figure is above 40 cm. The roof-fall height can be all the more considerable, the greater is the distance from canopy tip to coal face. If this critical tip to face interval can be measured, there is a possibility of preventing roof falls. The question now arising concerns the nature of the parameters that affect this critical tip to face distance.

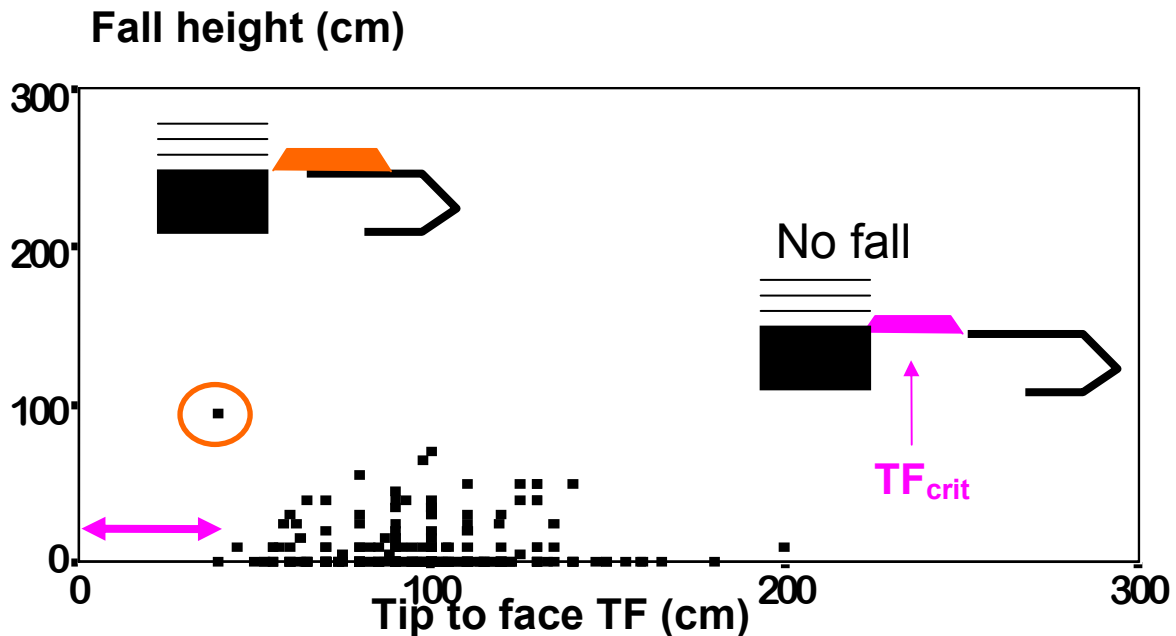
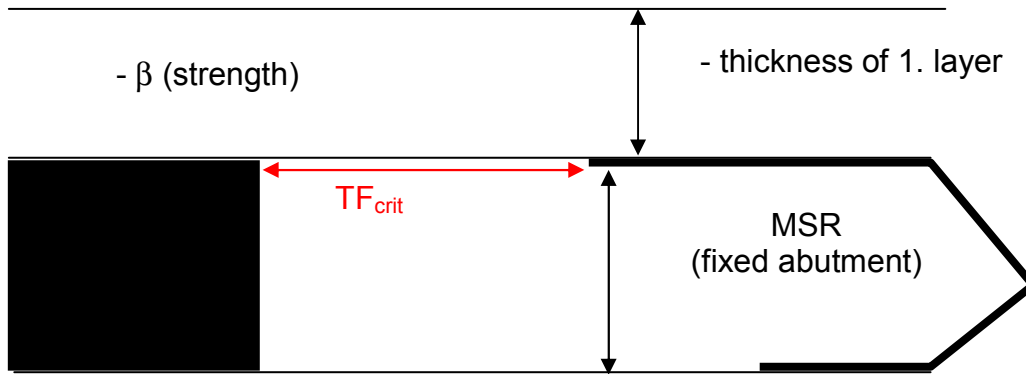

FIG. 6 - Roof fall geometry – relationship between tip to face distance (TF) and height of fall

### CRITICAL TIP-TO-FACE DISTANCE ( $TF_{crit}$ )

It has been accepted that the tendency of the roof to fail is dependent on the stability of the first series of strata between two solid abutments (Figure 7). These abutments are the coal face and the face supports. As a result, the stability of this beam, and therefore also the critical tip to face distance, is dependent on the thickness and strength of the first roof bed.



**Assumption:**  
 $TF_{crit} = f$  (strength and thickness 1. layer)

**FIG. 7 - Critical distance between canopy Tip and coal Face ( $TF_{crit}$ )**

The next stage was to compare the strengths and thicknesses of the first roof bed, as determined from strata sections, with the critical tip to face distances established by measurement (Figure 8). The strengths of the investigated roof beds varied from  $\beta = 36 \text{ N/mm}^2$  (soft shale) and  $\beta = 45 \text{ N/mm}^2$  (shale) to  $\beta = 63 \text{ N/mm}^2$  (sandy shale). Regression calculation methods were used to obtain an exponential equation that set the strength and thickness of the first roof bed in relation to the  $TF_{crit}$ .

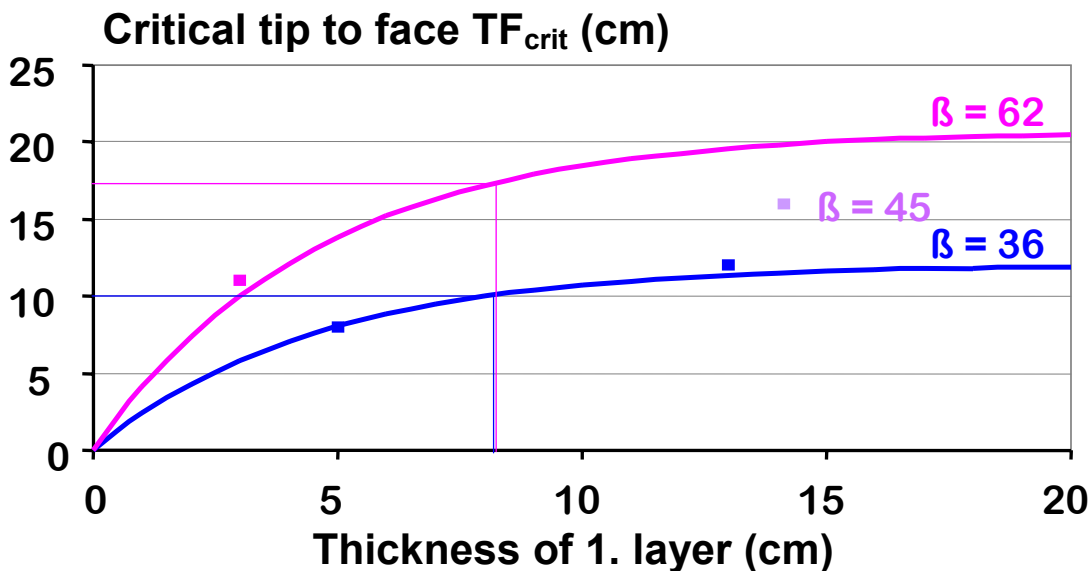

**FIG. 8 - Calculation of  $TF_{crit}$**

If the distance to the first stratum change is 70 cm, the critical tip to face distance in the case of sandy shale ( $\beta = 63 \text{ N/mm}^2$ ) is about 1.70 m (Figure 8). On a coal face with such a strong roof it is therefore unlikely that there will be roof fall problems, even at large tip to face distances. However, when the roof strata consists of soft shale ( $\beta = 36 \text{ N/mm}^2$ ) this distance is reduced to a mere 1 m. This means that longwall faces with such a roof composition will be much more prone to roof falls.

This assumption, which has been recognized for many years, has become quantifiable with the acquisition of the regression equation and the general theory now required verification using the measured data. To this effect the following hypothesis was formulated: If the measured tip to face distance is smaller than the calculated value, no roof fall can take place (Figure 9). Of the total of 3,137 data records taken, 2,416 were used for the verification process. In 736 of the cases the measured tip to face distance was smaller than the critical interval. In 728 of these instances (99 %) no roof falls occurred. Only in 8 cases (1 %) were rock falls recorded. In the 1,680 cases in which the measured tip to face distance was greater than the critical interval a total of 204 roof falls occurred

(12 %). The probability of a roof fall occurring is therefore 12 times greater when the critical tip to face distance, as measured underground, is exceeded. By comparison it can be stated that the probability of a roof fall occurring is very low (1 %) when the critical tip to face distance is not exceeded. The above hypothesis is thereby confirmed.

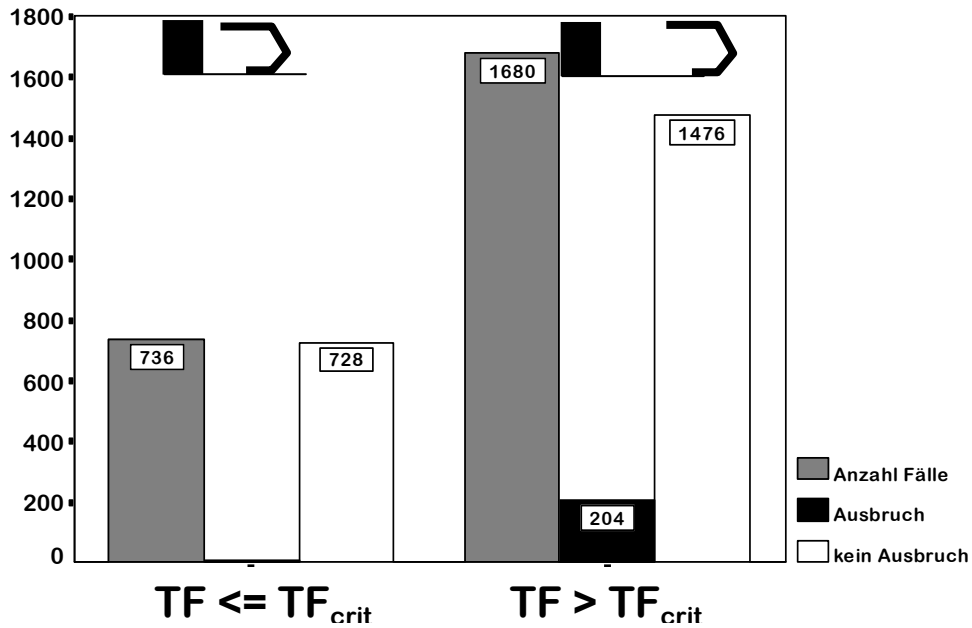

FIG. 9 - Hypothesis of TF<sub>crit</sub>

Under a given set of geological conditions the critical distance from canopy tip to coal face is therefore the key quantity for roof control and for selecting the most suitable support system for the existing underground conditions.

**CALCULATION OF ROOF FALL FREQUENCY**

Regrettably, operational conditions on the face mean that it is not always possible to avoid exceeding the critical tip to face distance in every underground situation. This is clarified in Figure 10, which plots roof-fall frequency against the tip to face distance. The measurements shown were taken from 3 longwall production faces on which the critical tip to face distance was approximately 70 cm, 80 cm and 90 cm respectively. Once the critical tip to face distance has been exceeded, however, the increase in roof fall frequency is very variable. The real question is, what influences the increase in roof fall frequency?

**Fall frequency FF > 0 cm (%)**

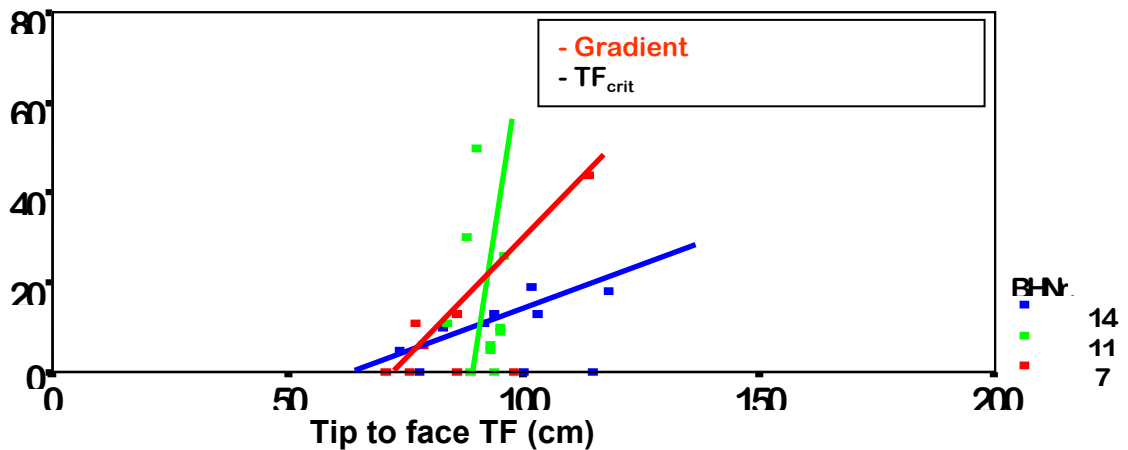

FIG. 10 - Roof-fall frequency gradient

In order to answer this it was necessary to investigate a number of additional criteria. The first of these concerned a factor that has long been recognized from rock mechanics engineers over the years, namely the angle between the direction of the fissures and the direction of longwall mining. Figure 11 shows the measured roof fall frequency as a function of the angle between the direction of mining and the direction of the fissures in gon (where 100gon = 90°). At an angle of 0 gon longwall-parallel fissures run into the coal face (under the fissures) and beds slipping from the roof are supported by the coal face. At an angle of + or - 200 gon the longwall-parallel fissures run into the goaf (on the fissures) and beds slipping from the roof are able to fall into the face cavity in front of the shield canopies. For reasons of simplification the index 1 was used to denote the favourable situation of "under the fissures" and the index 2 was used for the unfavourable situation of "on the fissures".

The measured roof fall frequencies in the central quadrants are evidently lower than those in the outer quadrants (Figure 11). Here the observed variation in RFF of 15 to 75 % is caused by differences in the other parameters eg MSR and stress. How great the effect of fissure direction is can be illustrated by taking as an example two underground measurements shown in Figure 11. When working 653's panel (circled) roof fall frequencies of between 15 and 45 % were observed. The adjacent 654's panel was worked in the opposite direction. Here the roof fall frequency was a maximum of 15 % - the same as the minimum frequency rate for the preceding panel. This is solely due to the change in working direction, since the supports and all other parameters were almost identical in both panels.

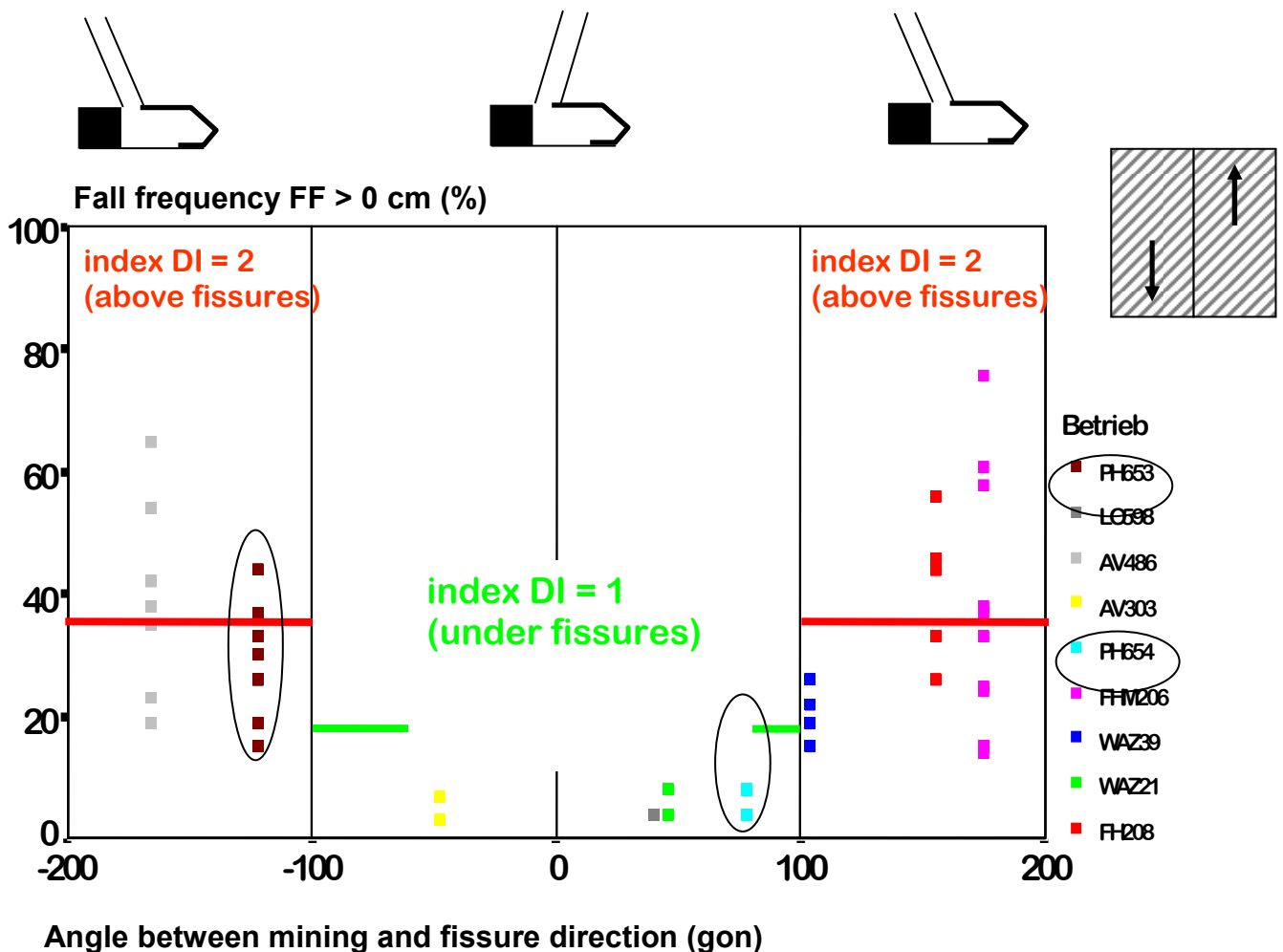

FIG. 11 - Influence of angle between fissure direction and direction of mining (DI index)

A calculation equation was established by a process of regression (Figure 12) incorporating the following parameters:

- calculated vertical rock pressure  $p_v$
- measured support resistance MSR



- fissure-direction index DI and
- the value by which the critical tip to face distance is exceeded underground ( $\Delta TF$ )

A calculation equation was established by a process of regression (Figure 12). The definiteness ratio of this equation is 86%, which is a very high figure when it comes to the evaluation of underground measurements. The following parametric studies of the factors involved illustrate how great an influence the latter have on the roof fall frequency.

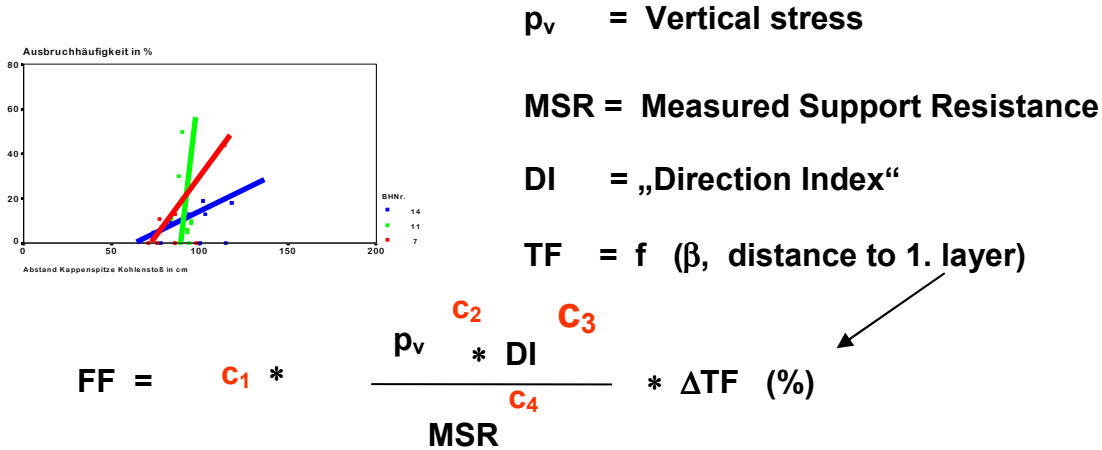

Determination coefficient = 86 %

FIG. 12 - Roof-fall frequency gradient FF – determinant equation variables

Figure 13 shows the varying increases in roof fall frequency once the critical tip to face distance of 60 cm has been exceeded. While there is a substantial rise in roof fall frequency at a low measured support resistance, this increase is clearly more moderate when the measured support resistance is high. Figure 14 shows the effect of measured support resistance on the roof fall frequency for a favourable (DI = 1) and unfavourable (DI = 2) direction of fissures. While doubling the measured support resistance from 350 to 700 kN/mm<sup>2</sup> has little impact when the fissure direction is favourable, the same operation produces a significant effect when the direction of the fissures is unfavourable.

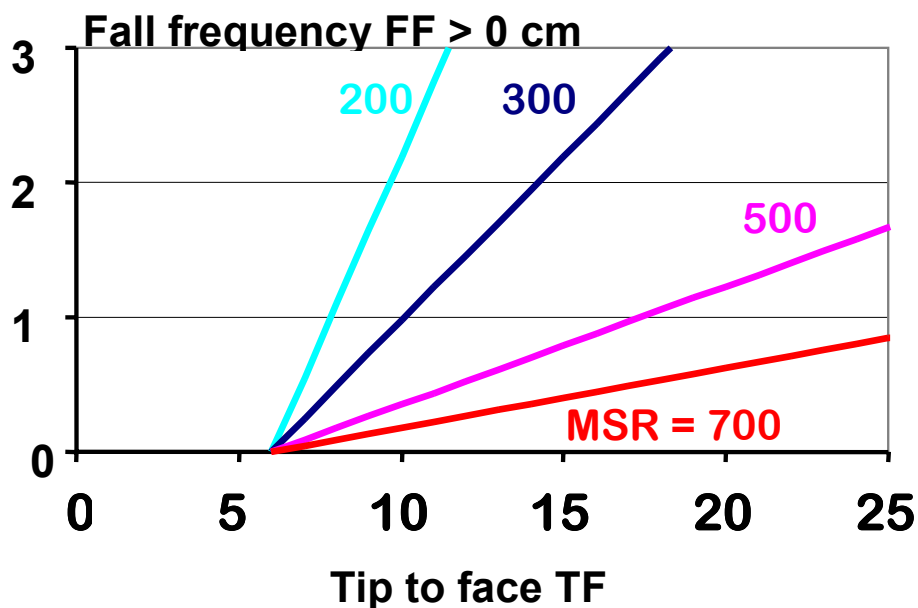

FIG. 13 - Parameter variation – MSR to FF and TF

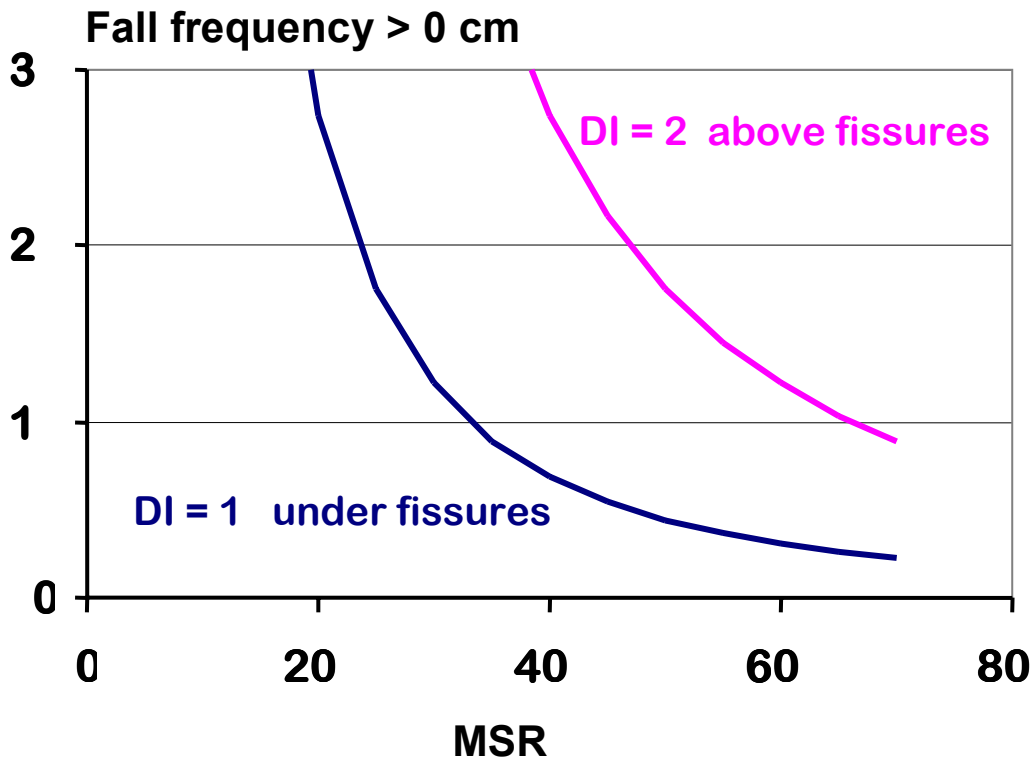

FIG. 14 - Parameter variation – DI to FF and MSR

#### CASE STUDY

A case study shows how the information obtained can be put to good effect for the benefit of the user. This depicts the calculated critical tip to face distance for two panels that were investigated using two strata sections obtained from 34 boreholes (Figure 15). Favourable geology means that no strata control problems are encountered in the light shaded area ( $TF_{crit} \geq 1.2$  m). However, as the strata series changes unfavourable areas also develop that require a critical tip to face distance of less than 60 cm in order to prevent roof falls. In these areas, which are identified by dark shading in the diagram, the face must either maintain a maximum tip to face distance of 60 cm or – in the event that the critical tip to face distance  $TF_{crit}$  of 60 cm is exceeded – significantly increase its measured support resistance, if it is to avoid roof falls. In certain circumstances this will mean recommending a stronger set of shield supports.

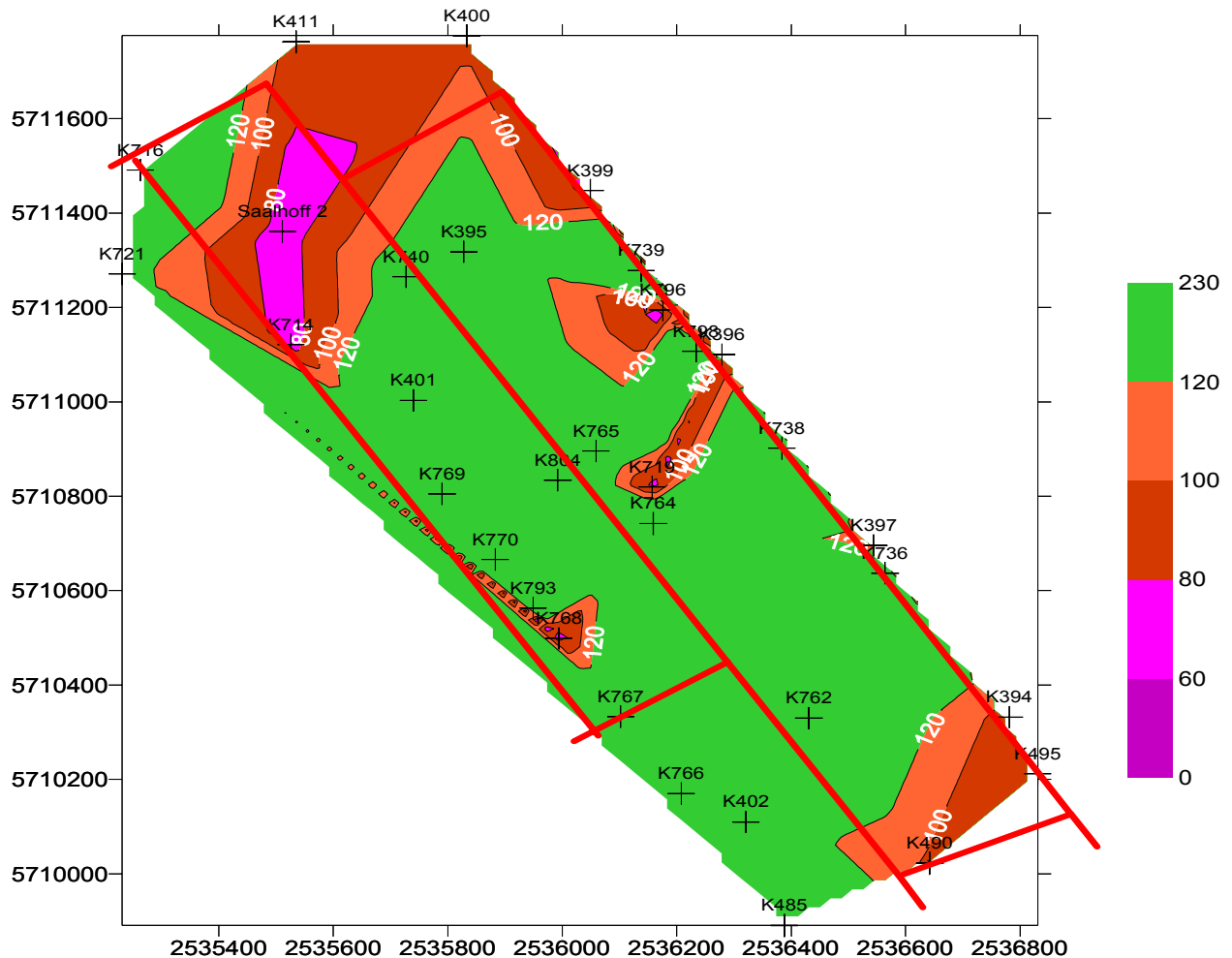

FIG. 15 - Case study 2 – critical distance between canopy tip and coal face (TFcrit)

### CONCLUSION

Armed with these results DMT is now able to predict the critical distance between the tip of the canopy and the coal face ( $TF_{crit}$ ), as well as the roof fall frequency, for all shield designs.

By applying the new calculation method it is now possible to compare alternative longwall layouts and different shield support types under pre-set geological conditions. Mining engineers on site are therefore in a position to make the necessary roof control preparations required to run the longwall operation to maximum efficiency. The results provide a useful basis for making practical recommendations and for selecting the most effective design of shield support.

### REFERENCES

- Jacobi, O, 1981. Praxis der Gebirgsbeherrschung, 2. Auflage in German. Strata control practice, 2nd edition, (Verlag Glückauf, Essen, Germany, ISBN 3-7739-0351)
- Irresberger, H, Gräwe, F, Migenda, P, 1994. Schreitausbau für den Steinkohlenbergbau in German. Powered supports for the coal industry (Verlag Glückauf, Essen, Germany, ISBN 3-7739-0611-0)
- Peng, SS, Chiang, HS, 1984. Longwall Mining (John Wiley & Sons, New York, USA, ISBN 0-471-86881-7)